

# Double row self-aligning ball bearings

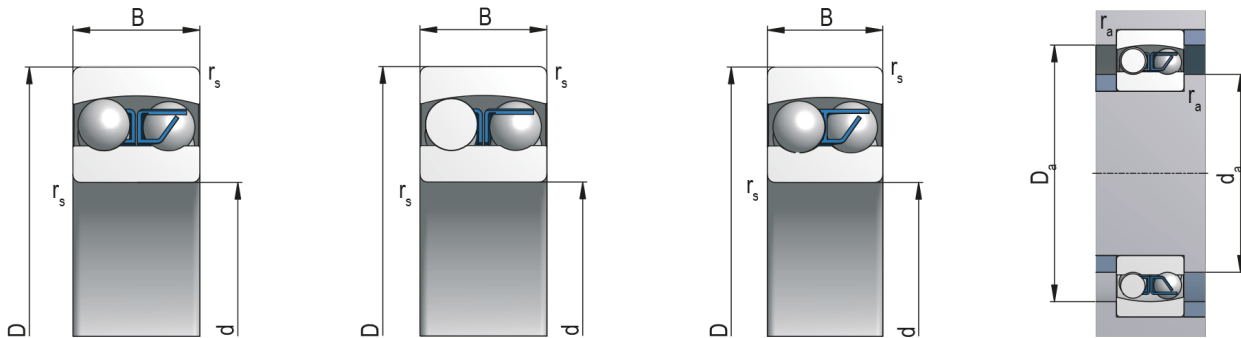

Bearing Designation	1304	- Cylindrical Bore
	1304K	- Tapered Bore (1:12)
		- 2RS

## Dimensions (mm)

d	20
D	52
B	15
r <sub>s</sub> min	1,1

## Abutment and Fillet Dimensions (mm)

d <sub>a</sub> min	27
D <sub>a</sub> max	45
r <sub>a</sub> max	1

## Basic Load Rating (kN)

C	12,42
C <sub>0</sub>	3,82

## Limiting Speed for Lubrication (min )<sup>-1</sup>

Grease	15000
Olej	18000

Weight [kg]	0,162
Adapter Sleeve	H304
Weight - K [kg]	0,159

## Coefficients

e	0,28
Y <sub>1</sub>	2,2
Y <sub>2</sub>	3,5
Y <sub>0</sub>	2,5

## Tolerance Class

Tolerance Class	Inner Ring									
	Cylindrical Bore									
	$\Delta_{dmp}$		$V_{dp}$			$V_{dmp}$	$K_{ia}$	$\Delta_{B_s}$		$V_{B_s}$
			Diameter Series							
			7,8,9	0,1	2,3,4					
max	min	max	max	max	max	max	min	max		
$\mu m$										
P0	0	-10	13	10	8	8	13	0	-120	20
P6	0	-8	10	8	6	6	8	0	-120	20

Tolerance Class	Inner Ring														
	Tapered Bore 1:12					Tapered Bore 1:30									
	$\Delta_{dmp}$		$\Delta_{d1mp} - \Delta_{dmp}$		$V_{dp}^{1)}$	$\Delta_{dmp}$		$\Delta_{d1mp} - \Delta_{dmp}$		$V_{dp}^{1)}$					
											max	min	max	min	max
											max	min	max	min	max
$\mu m$															
P0 = P6	21	0	21	0	13	-	-	-	-	-					

Tolerance Class	Outer Ring									
	$\Delta_{Dmp}$		$V_{Dp}$			bearings <sup>2)</sup> with seals	$V_{Dmp}$	$K_{ea}$	$\Delta_{CS}, V_{CS}$	
			Diameter Series							
			7,8,9	0,1	2,3,4					
	max	min	max	max	max	max	max			
$\mu m$										
P0	0	-13	16	13	10	20	10	25	Corresponds to $\Delta_{BS}, V_{BS}$ of the same bearing inner ring	
P6	0	-11	14	11	8	16	8	13		

1) Valid in any bore radial plane

2) P0 - Valid only for bearings in diameter series 2, 3 and 4 \* P6 - Valid only for bearings in diameter series 0, 1, 2, 3 and 4

## Radial Clearance - Cylindrical Bore

C2		normal		C3		C4		C5	
min	max	min	max	min	max	min	max	min	max
$\mu m$									
4	14	10	23	17	30	25	39	34	52

## Radial Clearance - Tapered Bore

C2		normal		C3		C4		C5	
min	max	min	max	min	max	min	max	min	max
$\mu m$									
7	17	13	26	20	33	28	42	37	55

## Tolerance Symbols and Their Meaning

$d$	nominal bore diameter	$H_4$	rated height of spherical-roller bearing
$d_1$	nominal diameter of larger theoretical tapered bore diameter	$\Delta_{Bs}$	inner ring single width deviation
$d_2$	nominal diameter of the shaft washer of double direction thrust bearings	$\Delta_{Cs}$	outer ring single width deviation
$\Delta_{ds}$	deviation of single bore diameter from nominal	$\Delta_{Ts}$	bearing single width deviation (total)
$\Delta_{dmp}$	mean cylindrical bore diameter deviation in single radial plane (for tapered bore $\Delta_{dmp}$ is valid for theoretical bore diameter)	$\Delta_{T1s}$	cone sub-unit effective width deviation
$\Delta_{d1mp}$	deviation of mean larger theoretical diameter of tapered bore	$\Delta_{T2s}$	cup sub-unit effective width deviation
$\Delta_{d2mp}$	mean shaft washer bore diameter deviation of double direction thrust bearings in single radial plane	$\Delta_{Hs}$	height deviation of single direction axial bearings from nominal value
$V_{dp}$	single bore diameter variation in single radial plane	$\Delta_{H1s}$	height deviation of single direction axial ball bearings with sphered housing washer from nominal value
$V_{dmp}$	mean cylindrical bore diameter variation	$\Delta_{H2s}$	height deviation of double direction axial bearings from nominal value
$V_{d2p}$	shaft washer bore diameter variation of double direction thrust bearings in single radial plane	$\Delta_{H3s}$	height deviation of double direction axial ball bearings with sphered housing washer from nominal value
$D$	nominal outside diameter	$\Delta_{H4s}$	height deviation of axial spherical-roller bearing from the rated value
$\Delta_{Ds}$	deviation of single outside diameter from the nominal dimension	$C$	outer ring nominal width
$\Delta_{Dmp}$	mean outside cylindrical surface diameter deviation in single plane	$V_{Bs}$	inner ring single width variation
$V_{Dp}$	single outside cylindrical surface diameter variation in single radial plane	$V_{Cs}$	outer ring single width variation
$V_{Dmp}$	mean outside cylindrical surface diameter variation	$K_{ia}$	radial runout of assembled bearing inner ring
$B$	inner ring nominal width	$K_{ea}$	radial runout of assembled bearing outer ring
$T$	total nominal width of tapered roller bearings	$S_i$	shaft washer raceway axial runout
$T_1$	nominal effective width of cup sub-unit	$S_e$	housing washer raceway axial runout
$T_2$	nominal effective width of cone sub-unit	$S_{ia}$	inner ring flat seat face axial runout of assembled bearing
$H$	rated width of unidirectional axial bearing	$S_{ea}$	outer ring flat seat face axial runout of assembled bearing
$H_1$	rated height of unidirectional ball axial bearing including the body ring	$S_d$	flat seat face axial runout
$H_2$	rated height of bidirectional axial bearing	$S_D$	runout of outside cylindrical surface towards outer ring face
$H_3$	rated height of bidirectional axial ball bearing including body rings	$S_s$	runout of supporting face towards seat face for single row tapered roller bearings