

# Double row angular contact ball bearing

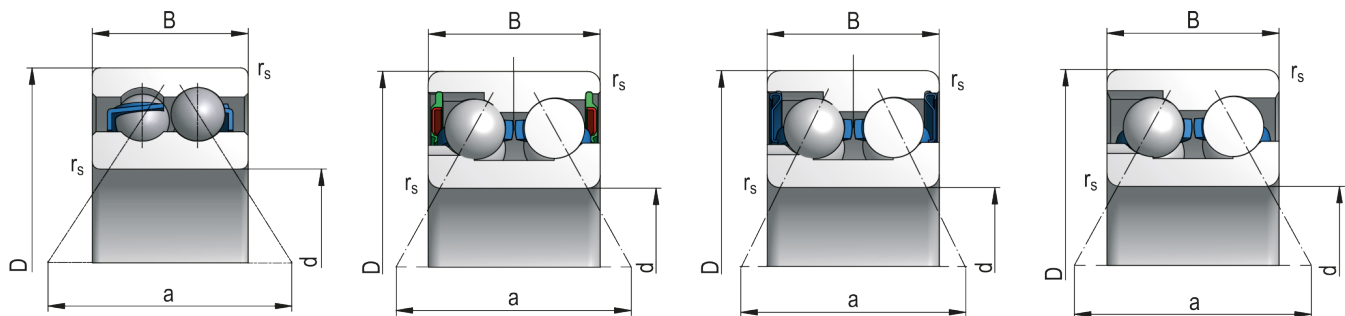

Bearing Designation	3202E	3202E-2RS
---------------------	-------	-----------

## Dimensions (mm)

d	15
D	35
B	15,9
r <sub>s</sub> min	1
a	24,4

## Abutment and Fillet Dimensions (mm)

d <sub>a</sub> min	19,5
D <sub>a</sub> max	26,5
r <sub>a</sub> max	0,5

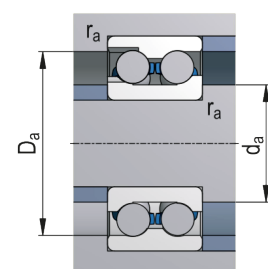

## Basic Load Rating (kN)

C	11,47
C <sup>0</sup>	9,37

## Limiting Speed for Lubrication (min<sup>-1</sup>)

Grease	13000
Oil	16000

Weight [kg]	0,070
-------------	-------

## Tolerance Class

Tolerance Class	Inner Ring									
	Cylindrical Bore									
	$\Delta_{dmp}$		$V_{dp}$			$V_{dmp}$	$K_{ia}$	$\Delta_{Bs}$		$V_{Bs}$
			Diameter Series							
	max	min	7,8,9	0,1	2,3,4	max	max	max	min	max
$\mu m$										
P0	0	-8	10	8	6	6	10	0	-120	20
P6	0	-7	9	7	5	5	7	0	-120	20

Tolerance Class	Inner Ring									
	Tapered Bore 1:12					Tapered Bore 1:30				
	$\Delta_{dmp}$		$\Delta_{d1mp} - \Delta_{dmp}$		$V_{dp}^{1)}$	$\Delta_{dmp}$		$\Delta_{d1mp} - \Delta_{dmp}$		$V_{dp}^{1)}$
	max	min	max	min	max	max	min	max	min	max
$\mu m$										
P0 = P6	-	-	-	-	-	-	-	-	-	-

Tolerance Class	Outer Ring									
	$\Delta_{Dmp}$		$V_{Dp}$			bearings <sup>2)</sup> with seals	$V_{Dmp}$	$K_{ea}$	$\Delta_{CS}, V_{CS}$	
			Diameter Series							
	max	min	7,8,9	0,1	2,3,4	max	max	max	max	
	$\mu m$									
P0	0	-11	14	11	8	16	8	20	Corresponds to $\Delta_{BS}, V_{BS}$ of the same bearing inner ring	
P6	0	-9	11	9	7	13	7	10		

1) Valid in any bore radial plane

2) P0 - Valid only for bearings in diameter series 2, 3 and 4 \* P6 - Valid only for bearings in diameter series 0, 1, 2, 3 and 4

## Axial Clearance

C2		normal		C3		C4	
min	max	min	max	min	max	min	max
$\mu m$							
1	12	6	23	13	31	27	47

## Tolerance Symbols and Their Meaning

$d$	nominal bore diameter	$H_4$	rated height of spherical-roller bearing
$d_1$	nominal diameter of larger theoretical tapered bore diameter	$\Delta_{Bs}$	inner ring single width deviation
$d_2$	nominal diameter of the shaft washer of double direction thrust bearings	$\Delta_{Cs}$	outer ring single width deviation
$\Delta_{ds}$	deviation of single bore diameter from nominal	$\Delta_{Is}$	bearing single width deviation (total)
$\Delta_{dmp}$	mean cylindrical bore diameter deviation in single radial plane (for tapered bore $\Delta_{dmp}$ is valid for theoretical bore diameter)	$\Delta_{T1s}$	cone sub-unit effective width deviation
$\Delta_{d1mp}$	deviation of mean larger theoretical diameter of tapered bore	$\Delta_{T2s}$	cup sub-unit effective width deviation
$\Delta_{d2mp}$	mean shaft washer bore diameter deviation of double direction thrust bearings in single radial plane	$\Delta_{Hs}$	height deviation of single direction axial bearings from nominal value
$V_{dp}$	single bore diameter variation in single radial plane	$\Delta_{H1s}$	height deviation of single direction axial ball bearings with sphered housing washer from nominal value
$V_{dmp}$	mean cylindrical bore diameter variation	$\Delta_{H2s}$	height deviation of double direction axial bearings from nominal value
$V_{d2p}$	shaft washer bore diameter variation of double direction thrust bearings in single radial plane	$\Delta_{H3s}$	height deviation of double direction axial ball bearings with sphered housing washer from nominal value
$D$	nominal outside diameter	$\Delta_{H4s}$	height deviation of axial spherical-roller bearing from the rated value
$\Delta_{Ds}$	deviation of single outside diameter from the nominal dimension	$C$	outer ring nominal width
$\Delta_{Dmp}$	mean outside cylindrical surface diameter deviation in single plane	$V_{Bs}$	inner ring single width variation
$V_{Dp}$	single outside cylindrical surface diameter variation in single radial plane	$V_{Cs}$	outer ring single width variation
$V_{Dmp}$	mean outside cylindrical surface diameter variation	$K^{ia}$	radial runout of assembled bearing inner ring
$B$	inner ring nominal width	$K^{ea}$	radial runout of assembled bearing outer ring
$T$	total nominal width of tapered roller bearings	$S_t^{ea}$	shaft washer raceway axial runout
$T_1$	nominal effective width of cup sub-unit	$S_t^e$	housing washer raceway axial runout
$T_2$	nominal effective width of cone sub-unit	$S_{ia}^e$	inner ring flat seat face axial runout of assembled bearing
$H$	rated width of unidirectional axial bearing	$S_{ea}^e$	outer ring flat seat face axial runout of assembled bearing
$H_1$	rated height of unidirectional ball axial bearing including the body ring	$S_d^{ea}$	flat seat face axial runout
$H_2$	rated height of bidirectional axial bearing	$S_D$	runout of outside cylindrical surface towards outer ring face
$H_3$	rated height of bidirectional axial ball bearing including body rings	$S_s$	runout of supporting face towards seat face for single row tapered roller bearings