

Double row angular contact ball bearing

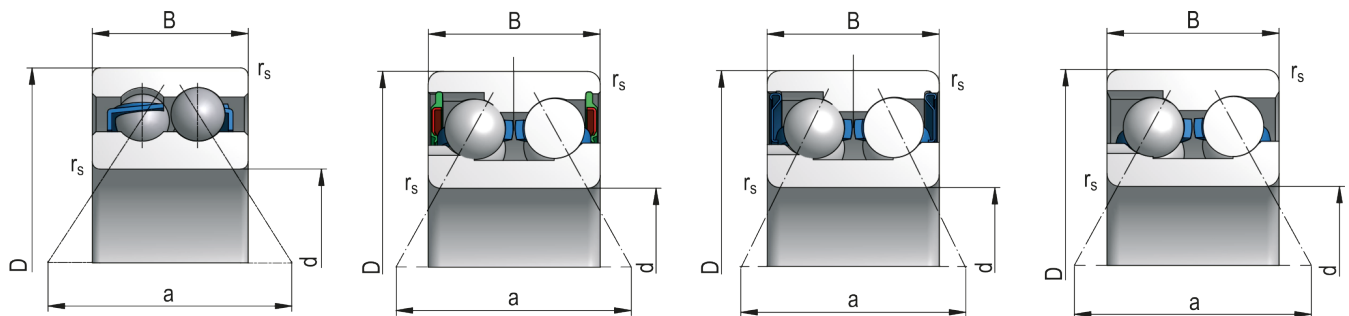

Bearing Designation	3203	3203-2RS
---------------------	------	----------

Dimensions (mm)

d	17
D	40
B	17,5
r _s min	0,6
a	24,4

Abutment and Fillet Dimensions (mm)

d _a min	24,5
D _a max	33,5
r _a max	0,6

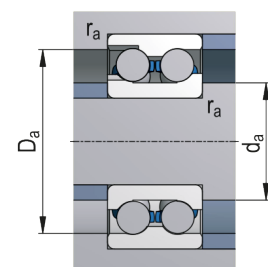

Basic Load Rating (kN)

C	14,21
C ⁰	8,74

Limiting Speed for Lubrication (min⁻¹)

Grease	11000
Oil	13000

Weight [kg]	0,095
-------------	-------

Tolerance Class

Tolerance Class	Inner Ring									
	Cylindrical Bore									
	Δ_{dmp}		V_{dp}			V_{dmp}	K_{ia}	Δ_{Bs}		V_{Bs}
			Diameter Series							
	max	min	7,8,9	0,1	2,3,4	max	max	max	min	max
μm										
P0	0	-8	10	8	6	6	10	0	-120	20
P6	0	-7	9	7	5	5	7	0	-120	20

Tolerance Class	Inner Ring									
	Tapered Bore 1:12					Tapered Bore 1:30				
	Δ_{dmp}		$\Delta_{d1mp} - \Delta_{dmp}$		$V_{dp}^{1)}$	Δ_{dmp}		$\Delta_{d1mp} - \Delta_{dmp}$		$V_{dp}^{1)}$
	max	min	max	min	max	max	min	max	min	max
μm										
P0 = P6	-	-	-	-	-	-	-	-	-	-

Tolerance Class	Outer Ring									
	Δ_{Dmp}		V_{Dp}			bearings ²⁾ with seals	V_{Dmp}	K_{ea}	Δ_{CS}, V_{CS}	
			Diameter Series							
	max	min	7,8,9	0,1	2,3,4	max	max			
	μm									
P0	0	-11	14	11	8	16	8	20	Corresponds to Δ_{BS}, V_{BS} of the same bearing inner ring	
P6	0	-9	11	9	7	13	7	10		

1) Valid in any bore radial plane

2) P0 - Valid only for bearings in diameter series 2, 3 and 4 * P6 - Valid only for bearings in diameter series 0, 1, 2, 3 and 4

Axial Clearance

C2		normal		C3		C4	
min	max	min	max	min	max	min	max
μm							
1	12	6	23	13	31	27	47

Tolerance Symbols and Their Meaning

d	nominal bore diameter	H_4	rated height of spherical-roller bearing
d_1	nominal diameter of larger theoretical tapered bore diameter	Δ_{Bs}	inner ring single width deviation
d_2	nominal diameter of the shaft washer of double direction thrust bearings	Δ_{Cs}	outer ring single width deviation
Δ_{ds}	deviation of single bore diameter from nominal	Δ_{Is}	bearing single width deviation (total)
Δ_{dmp}	mean cylindrical bore diameter deviation in single radial plane (for tapered bore Δ_{dmp} is valid for theoretical bore diameter)	Δ_{T1s}	cone sub-unit effective width deviation
Δ_{d1mp}	deviation of mean larger theoretical diameter of tapered bore	Δ_{T2s}	cup sub-unit effective width deviation
Δ_{d2mp}	mean shaft washer bore diameter deviation of double direction thrust bearings in single radial plane	Δ_{Hs}	height deviation of single direction axial bearings from nominal value
V_{dp}	single bore diameter variation in single radial plane	Δ_{H1s}	height deviation of single direction axial ball bearings with sphered housing washer from nominal value
V_{dmp}	mean cylindrical bore diameter variation	Δ_{H2s}	height deviation of double direction axial bearings from nominal value
V_{d2p}	shaft washer bore diameter variation of double direction thrust bearings in single radial plane	Δ_{H3s}	height deviation of double direction axial ball bearings with sphered housing washer from nominal value
D	nominal outside diameter	Δ_{H4s}	height deviation of axial spherical-roller bearing from the rated value
Δ_{Ds}	deviation of single outside diameter from the nominal dimension	C	outer ring nominal width
Δ_{Dmp}	mean outside cylindrical surface diameter deviation in single plane	V_{Bs}	inner ring single width variation
V_{Dp}	single outside cylindrical surface diameter variation in single radial plane	V_{Cs}	outer ring single width variation
V_{Dmp}	mean outside cylindrical surface diameter variation	K^{ia}	radial runout of assembled bearing inner ring
B	inner ring nominal width	K^{ea}	radial runout of assembled bearing outer ring
T	total nominal width of tapered roller bearings	S_t^{ea}	shaft washer raceway axial runout
T_1	nominal effective width of cup sub-unit	S_t^e	housing washer raceway axial runout
T_2	nominal effective width of cone sub-unit	S_{ia}^e	inner ring flat seat face axial runout of assembled bearing
H	rated width of unidirectional axial bearing	S_{ea}^e	outer ring flat seat face axial runout of assembled bearing
H_1	rated height of unidirectional ball axial bearing including the body ring	S_d^{ea}	flat seat face axial runout
H_2	rated height of bidirectional axial bearing	S_D	runout of outside cylindrical surface towards outer ring face
H_3	rated height of bidirectional axial ball bearing including body rings	S_s	runout of supporting face towards seat face for single row tapered roller bearings